



# MOTORTRONICS™

Solid State AC Motor Control

## MWH Series



Motor Winding  
Heater Controls

Ratings from 3 - 900 HP

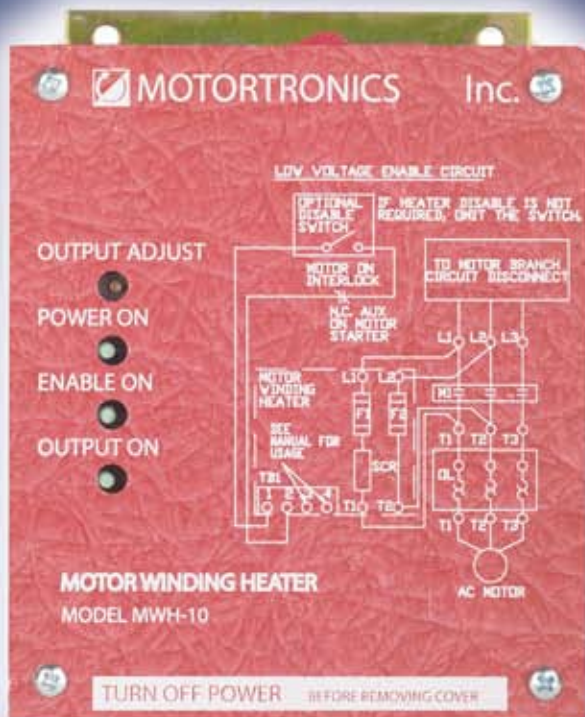

*The MWH Series keep motors warm & moisture-free during extended shut down periods.*

Use On Any AC Motor

- Simple to Wire/Easy Retrofit
- Cost-Effective Alternative to Strip Heaters
- Protects Motors from Problems Due to Condensation Build-up
- Reliable, Maintenance-Free Operation

### Protect Your Motors

Even the best motor winding insulation materials become water permeable with repeated exposure to temperature extremes and moisture. If the ambient temperature is below the "dew point" when a motor is turned off, condensation will form inside the motor as it cools down. When the motor is re-energized, the moisture heats up and permeates the windings, eventually shorting and damaging the motor. Airborne corrosive elements like salt and chemicals can also combine with condensation and erode the rotor and bearings, leading to premature motor failure.

The **MWH Series** provides a cost effective solution to these problems by preventing condensation build-up in motors. By applying a low level current to the motor windings during extended shut down periods, the MWH Series keeps AC motors warm and moisture-free.

### Fully Automatic Operation

Designed for fully automatic operation, the MWH Series turns on when the motor starter is turned off. A built-in one minute timer ensures that the motor magnetic field has collapsed before it injects DC power into the windings. When the motor is restarted, the MWH Series instantly turns off. No operator interface is required... the MWH Series is in control.

### Built-in Overload Sensing

The MWH Series had an optional shutdown input that can be connected to the N.O. auxiliary contact on the motor starter's thermal overload relay. This will disable the motor winding heater control, preventing any additional heating in the motor and allowing for a faster motor cool down period. The MWH Series then goes back on-line after the overload relay is reset.

### Ideal Alternative to Strip Heaters

Eliminate the cost and hassle of installing strip heaters into your motors. Simply wire up the MWH Series to generate heat throughout the motor stator windings. The heat is dissipated evenly without the "hot spots" caused by strip heaters. Conduction of heat to the rotor, bearings and shaft is also more effective which means maximized protection for the whole motor.

# MWH

## Simple Connections

### Series

#### EASY TO INSTALL

Whether retrofitting an existing starter or installing a new one, the MWH Series is easy to apply. Just wire it in parallel to the magnetic starter's line and load connection, connect the necessary auxiliary contacts and installation is complete.

#### SIMPLE ADJUSTMENT

Output voltage is factory set to maintain a +5° to 10°C differential above ambient temperature. This adjustment can be used to trim the control as required for each application.

#### SELF PROTECTED

In addition to built-in fuse protection, the MWH Series features an RC snubber circuit across the SCR which protects it from any rapid rate of change in the system voltage. A metal oxide varistor (MOV) protects the unit against voltage spikes for reliable, maintenance-free operation.

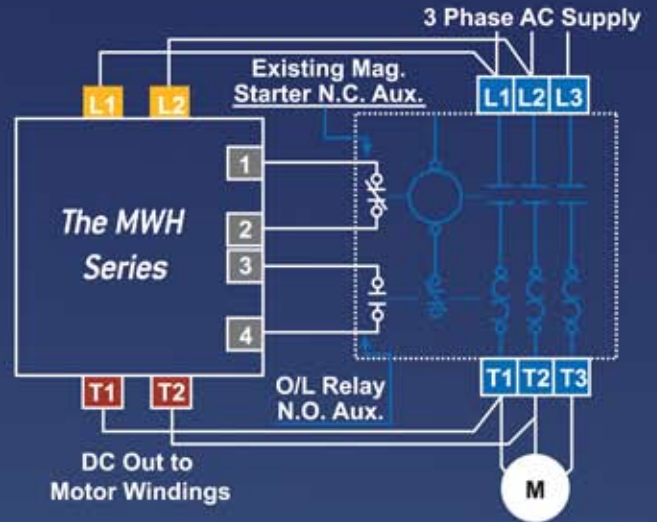

## How to Order

Standard units are dual voltage rated for 240V /480V operation and can be used for 208V applications. To order 380V, 415V or 575V units, add voltage designation to the end of the part number (example: MWH-10-P-575).

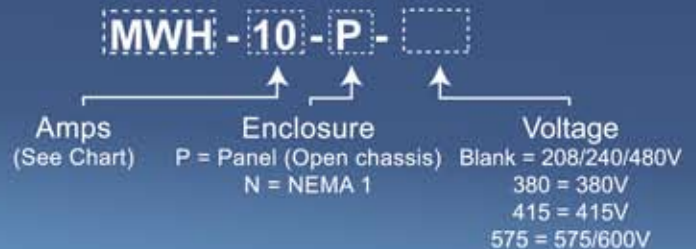

Model Number	Max Amp Rating	Motor Horsepower/Voltage				Dimensions (Inch)					
		208V	240V	480V	575V	Panel Mount			NEMA 1		
						H	W	D	H	W	D
MWH - 10	10	3 - 40	5 - 50	10 - 100	15 - 125	6.2	4.5	6	1.1	7	7
MWH - 25	25	50 - 100	60 - 125	125 - 250	150 - 300	8	6	6	1.1	7	7
MWH - 50	50	125 - 200	150 - 250	300 - 500	350 - 600	10	8	7.9	1.5	10	8
MWH - 80	80	250 - 300	300 - 400	600 - 800	700 - 900	10	8	9.3	20	10	10

Dimensions shown are in inches and are for reference only. Contact factory for exact dimensions.

#### CORPORATE HEADQUARTERS

#### Motortronics / Phasetronics

1600 Sunshine Drive  
Clearwater, Florida 33765  
Tel: 727.573.1819 or 888.767.7792  
Fax: 727.573.1803 or 800.548.4104  
E-mail: sales@motortronics.com  
www.motortronics.com

#### INTERNATIONAL LOCATIONS

**Motortronics Int'l Korea Co Ltd**  
601, Daeryung Techno Tower 5-cha  
Gasam-dong, Geumcheon-gu  
Seoul, Korea 9153-774  
Tel: 82-2-867-5808 / Fax: 82-2-867-6004  
www.motortronics-korea.com



#### MOTORTRONICS™

Solid State AC Motor Control

#### M & P Machinery & Electronics Control

113 Zaoshan Road  
Qingdao, China 266100  
Tel: 86-532-87660633  
Fax: 86-532-87660733  
www.mp-cn.com